

## Profilscharniere und Gelenkbänder nach DIN 31211

Gelenkbänder nach DIN 31211-N1  
mit vernietetem Stift

FES mit festem Stahlstift

FMS mit festem Messingstift

Artikel Nr.			Abmessungen in mm						
Art.Nr.	Ausführung		Werkstoff	A	B1	B2	C	D	Stift Ø
			unbehandelt Stahl						
86.1000.	FES	FMS	.00	40	20	20	3	8	4
86.1001.	FES	FMS	.00	40	20	40	3	8	4
86.1002.	FES	FMS	.00	40	40	40	3	8	4
86.1003.	FES	FMS	.00	60	30	30	5	12	6
86.1004.	FES	FMS	.00	60	30	60	5	12	6
86.1005.	FES	FMS	.00	60	60	60	5	12	6
86.1006.	FES	FMS	.00	80	40	40	7	16	8
86.1007.	FES	FMS	.00	80	40	80	7	16	8
86.1008.	FES	FMS	.00	80	80	80	7	16	8
86.1009.	FES	FMS	.00	100	110	110	10	26	13

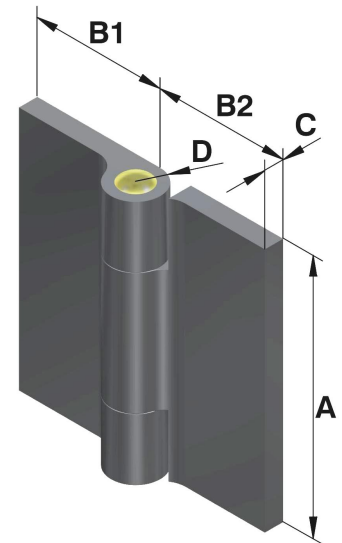

Gelenkbänder nach DIN 31211-N2  
versetzt montiert mit vernietetem Stift

FES mit festem Stahlstift

FMS mit festem Messingstift

Artikel Nr.			Abmessungen in mm						
Art.Nr.	Ausführung		Werkstoff	A	B1	B2	C	D	Stift Ø
			unbehandelt Stahl						
86.1010.	FES	FMS	.00	40	20	20	3	8	4
86.1011.	FES	FMS	.00	40	20	40	3	8	4
86.1012.	FES	FMS	.00	40	40	40	3	8	4
86.1013.	FES	FMS	.00	60	30	30	5	12	6
86.1014.	FES	FMS	.00	60	30	60	5	12	6
86.1015.	FES	FMS	.00	60	60	60	5	12	6
86.1016.	FES	FMS	.00	80	40	40	7	16	8
86.1017.	FES	FMS	.00	80	40	80	7	16	8
86.1018.	FES	FMS	.00	80	80	80	7	16	8
86.1019.	FES	FMS	.00	100	110	110	10	26	13

